



S.G.A.GOVERNMENT DEGREE COLLEGE

(Re-accredited by NAAC with 'A' Grade, Affiliated to Andhra University)

YELLAMANCHILI - 531055, ANDHRA PRADESH



DEPARTMENT OF ENGLISH

CIRCULAR

dated 21/03/2022

This is to inform the students of first year that the department of English is going to conduct a soft skills programme in English spoken English as well as employment skills. It includes telephone etiquette, interview skills, behavioural skill, interactive skills etc., Henceforth, with the instructions of the Principal of our college; the department of English is pleased to conduct the programme at zero hours of the college. Whoever interested in this programme, may consult the HOD of the department or Sri K.Premasagar to register their names.

G. SATYANARAYANA
HOD, Department of English
S.G.A. Govt. Degree College
Yellamanchilli, Visakhapatnam.

Principal
S.G.A. Govt. Degree College
Yellamanchilli-531 055
Anakapalli District. (A.P.)



S.G.A.GOVERNMENT DEGREE COLLEGE

(Re-accredited by NAAC with 'A' Grade, Affiliated to Andhra University)

YELLAMANCHILI - 531055, ANDHRA PRADESH



Teaching Interview skills and body language



S.G.A.GOVERNMENT DEGREE COLLEGE

(Re-accredited by NAAC with 'A' Grade, Affiliated to Andhra University)

YELLAMANCHILI - 531055, ANDHRA PRADESH



LIST OF STUDENTS ENROLLED

S.No.	Name of the Student	Hall ticket no.	Group
1	B.TEJESWINI	721135405082	I BSC
2	B.TEJOMAYEE	721135405083	I BSC
3	B.NAGA SHIVA GAYATHRI	721135405084	I BSC
4	B.SUKANYA	721135405085	I BSC
5	B.NOOKARATNAM	721135405086	I BSC
6	B.TEJASVI	721135405087	I BSC
7	B.LEELA PRAVEENA	721135405088	I BSC
8	B. DIVYA KRUPA	721135405089	I BSC
9	B.LAVANYA	721135405090	I BSC
10	CH.SWATHI	721135405091	I BSC
11	CH. MOKSHASRI	721135405092	I BSC
12	D.SIVAJI	721135405093	I BSC
13	D.NISSI ALEKHYA	721135405094	I BSC
14	E.HEMA VARAHA DURGA	721135405095	I BSC
15	G.EMMI VINOLINI	721135405096	I BSC
16	G.DHIKSHITHA	721135405097	I BSC
17	G.KIRANKUMAR	721135405098	I BSC
18	G.RANI	721135405099	I BSC
19	J.SINDHU	721135405100	I BSC
20	K. VASANTHA	721135405101	I BSC
21	K.LAKSHMI	721135405102	I BSC
22	K.LORIYA	721135405103	I BSC
23	K.MOUNIKA	721135405104	I BSC
24	K.KUMARI SREELAKSHMI	721135405105	I BSC
25	KDIVYA	721135405106	I BSC
26	L.YASAWINI	721135405107	I BSC
27	M.DEVI	721135405108	I BSC
28	M.NAGALAKSHMI	721135405109	I BSC
29	M.PUSHPALATHA	721135405110	I BSC
30	M.SRAVANI SAI	721135405111	I BSC
31	M. SIVA SRAVANI	721135405112	I BSC
32	M. NAVITHA	721135405113	I BSC
33	P.PAVANI	721135405114	I BSC
34	P.RATNA MALATHI NAVEENA	721135405115	I BSC
35	S.DIVYA	721135405116	I BSC
36	T.LOHITHA SRI	721135405117	I BSC
37	V.SAI	721135405118	I BSC
38	V.VINEEL	721135405119	I BSC
39	V.JAYASRI	721135405120	I BSC
40	V.TULASI	721135405121	I BSC



S.G.A.GOVERNMENT DEGREE COLLEGE

(Re-accredited by NAAC with 'A' Grade, Affiliated to Andhra University)

YELLAMANCHILI - 531055, ANDHRA PRADESH



Jawaharlal knowledge center

JKC Activities regarding Life skills

QUIZ Competitions





S.G.A.GOVERNMENT DEGREE COLLEGE

(Re-accredited by NAAC with 'A' Grade, Affiliated to Andhra University)

YELLAMANCHILI - 531055, ANDHRA PRADESH



Group Discussion





S.G.A.GOVERNMENT DEGREE COLLEGE

(Re-accredited by NAAC with 'A' Grade, Affiliated to Andhra University)

YELLAMANCHILI - 531055, ANDHRA PRADESH



Publicity Speaking





S.G.A.GOVERNMENT DEGREE COLLEGE

(Re-accredited by NAAC with 'A' Grade, Affiliated to Andhra University)

YELLAMANCHILI - 531055, ANDHRA PRADESH



**Our College Student P.Tulasi III B.Sc (MPC) got Prize Money in JNANABHERI competition conducted by the Government of Andhra Pradesh
Getting Memento from the Chief Minister of Andhra Pradesh N.Chandra Babu Naidu**



INNOVATIVE SKILLS

WORKING MODELS

S.NO	DATE	PROJECT NAME	GROUP	NUMBER OF STUDENTS INVOLVED
1.	28-10-2021	“Mind concentration game with moving ring”	MPCs	7
2.	09-11-2021	“Hydraulic traffic reducing system” and “conversion of solar energy into mechanical energy”	MPC	10
3.	23-11-2021	“Hydro electricity” and “Hydraulic lift “	MPCs	14
4.	06-12-2021	“Prevention of accidents in hilly areas” and “3D-hologram “	MPC	10
5.	10-12-2021	“Rain detector” and “hydraulic JCB”	MPCs	14

Lecturer in Physics
S.G.A GDC
YELLAMANCHILI

Principal
S.G.A Govt. Degree College
YELLAMANCHILI - 531 055
Vizakhapatnam District



S.G.A.GOVERNMENT DEGREE COLLEGE

(Re-accredited by NAAC with 'A' Grade, Affiliated to Andhra University)

YELLAMANCHILI - 531055, ANDHRA PRADESH



Student working model on “ MIND CONCENTRATION GAME WITH MOVING RING”prepared by Balaji team dated : 28-10-2021.

Lecturer in Physics
S.G.A. G.D.C.
YELLAMANCHILI

Principal
S.G.A. Govt. Degree College
YELLAMANCHILI - 531 055
Vizakhapatnam District



S.G.A.GOVERNMENT DEGREE COLLEGE

(Re-accredited by NAAC with 'A' Grade, Affiliated to Andhra University)

YELLAMANCHILI - 531055, ANDHRA PRADESH



Student working model on “HYDRALIC TRAFFIC REDUCING SYSTEM” AND “CONVERSION OF SOLAR ENERGY INTO MECHANICAL ENERGY” respectively prepared by Padma team and Gayathri team dated : 09-11-2021.

Lecturer in Physics
SGA GDC
YELLAMANCHILI

Principal
S.G.A Govt. Degree College
YELLAMANCHILI - 531 055
Vizakhapatnam District



S.G.A.GOVERNMENT DEGREE COLLEGE

(Re-accredited by NAAC with 'A' Grade, Affiliated to Andhra University)

YELLAMANCHILI - 531055, ANDHRA PRADESH



Student working model on **“HYDRO ELECTRICITY” AND “HYDRALIC LIFT”** respectively prepared by Ganesh Sri Saiteam and Naga Durga team dated : 23-11-2021.

Lecturer in Physics
SGA GDC
YELLAMANCHILI

Principal
S.G.A Govt. Degree College
YELLAMANCHILI - 531 055
Vizakhapatnam District.



S.G.A.GOVERNMENT DEGREE COLLEGE

(Re-accredited by NAAC with 'A' Grade, Affiliated to Andhra University)

YELLAMANCHILI - 531055, ANDHRA PRADESH



Student working model on "**PREVENTION OF ACCIDENTS IN HILLY AREAS**" AND "**3D-HOLOGRAM**" Respectively prepared by Krishnaveni team and Uma Devi team

dated :06-12-2021.

Lecturer in Physics
S.G.A. G.D.C
YELLAMANCHILI

Principal
S.G.A. Govt. Degree College
YELLAMANCHILI - 531 055
Vizakhapatnam District



S.G.A.GOVERNMENT DEGREE COLLEGE

(Re-accredited by NAAC with 'A' Grade, Affiliated to Andhra University)

YELLAMANCHILI - 531055, ANDHRA PRADESH



Student working models on **“RAIN DETECTOR” AND “HYDRALIC JCB”** Respectively are prepared by Lakshmi team and Leela Lakshmi team dated : 10-12-2021.

Lecturer in Physics
SGA GDC
YELLAMANCHILI

Principal
S.G.A Govt. Degree College
YELLAMANCHILI - 531 055
Vizakhapatnam District



S.G.A.GOVERNMENT DEGREE COLLEGE

(Re-accredited by NAAC with 'A' Grade, Affiliated to Andhra University)

YELLAMANCHILI - 531055, ANDHRA PRADESH



Project Name

Water Overflow Alarm Indicator



Project Guided by Project done by Sri P.S.Jaggarao 1. M. Varma (II-B.Sc- MPCs)

HOD Department of Physics. 2. M. Sandeep (II-B.Sc- MPCs)

Sri K .

Venkanna 3. D. Prasad (II-B.Sc- MPCs) Lecturer in Physics



Water Overflow Alarm Indicator

Aim:Setting up of water level alarm indicator in our college campus at two places to minimize wastage of water and power

Introduction

We the group of three members are engaged to do Water Level over flow Indicator by Department of Physics. We have implemented this at two overhead water tanks in our college campus. Nowadays everybody has overhead tank at their homes. But everyone who has a water tank top of their homes knows the kind of problems that they face. Initially there is no system to track the water in the tank. Second problem is that when their water pump is started they have no idea when it gets filled up. Sometimes there are situations where the pump keeps on *pumping water to the tank* and the water starts *spilling out from the tank*. There is **wastage of energy** as well as **wastage of water**.

Components Required:

Buzzer, wire, nails...

Working

Now as the water starts to rise the sensors start to get in contact with the water and the transistors are activated and there is a flow of current in the transistors making the LED's light up. Here in between the transistor and the LED there is a current limiting resistor 470 ohms, the job of the resistor is to check that the LED does not get over voltage and destroy the LED. The transistor is biased by a 470K resistor with the ground and the sensing part is taken from the collector with a 33 ohms resistor going directly to the tank.

The Buzzer Part

Here you can add any of the normal buzzers that are readily available in the market and if it is not then you can make yourself with a simple 555 IC. We are giving a small circuit diagram, it is really simple to make it with a minimum components. It is a simple audio oscillator. We have also provided a circuit diagram.

The Power Supply

This section contains a transformer converting the mains voltage 220V brings down to 9V. There is a bridge rectifier containing 4 diodes and making the Alternating current to Direct Current. After the filtering the voltage is then directly fed to the voltage regulator (7805) with a filtering capacitor. From the regulator IC the output voltage is then again filtered with a capacitor and is fed to the circuit. This comprises the power supply of the device.

Outcomes

We minimized the water wastage and power wastage in our campus



INNOVATIVE SKILLS

WORKING MODELS

S.NO	DATE	PROJECT NAME	GROUP	NUMBER OF STUDENTS INVOLVED
1.	28-10-2021	“Mind concentration game with moving ring”	MPCs	7
2.	09-11-2021	“Hydraulic traffic reducing system” and “conversion of solar energy into mechanical energy”	MPC	10
3.	23-11-2021	“Hydro electricity” and “Hydraulic lift “	MPCs	14
4.	06-12-2021	“Prevention of accidents in hilly areas” and “3D-hologram “	MPC	10
5.	10-12-2021	“Rain detector” and “hydraulic JCB”	MPCs	14

Lecturer in Physics
SGA GDC
YELLAMANCHILI

Principal
S.G.A Govt. Degree College
YELLAMANCHILI - 531 055
Vizakhapatnam District



S.G.A.GOVERNMENT DEGREE COLLEGE

(Re-accredited by NAAC with 'A' Grade, Affiliated to Andhra University)

YELLAMANCHILI - 531055, ANDHRA PRADESH



Student working model on “ MIND CONCENTRATION GAME WITH MOVING RING”prepared by Balaji team dated : 28-10-2021.

Lecturer in Physics
S.G.A. G.D.C.
YELLAMANCHILI

Principal
S.G.A. Govt. Degree College
YELLAMANCHILI - 531 055
Vizakhapatnam District



S.G.A.GOVERNMENT DEGREE COLLEGE

(Re-accredited by NAAC with 'A' Grade, Affiliated to Andhra University)

YELLAMANCHILI - 531055, ANDHRA PRADESH



Student working model on “HYDRALIC TRAFFIC REDUCING SYSTEM” AND “CONVERSION OF SOLAR ENERGY INTO MECHANICAL ENERGY” respectively prepared by Padma team and Gayathri team dated : 09-11-2021.

Lecturer in Physics
SGA GDC
YELLAMANCHILI

Principal
S.G.A Govt. Degree College
YELLAMANCHILI - 531 055
Vizakhapatnam District



S.G.A.GOVERNMENT DEGREE COLLEGE

(Re-accredited by NAAC with 'A' Grade, Affiliated to Andhra University)

YELLAMANCHILI - 531055, ANDHRA PRADESH



Student working model on **“HYDRO ELECTRICITY”** AND **“HYDRALIC LIFT”** respectively prepared by Ganesh Sri Saiteam and Naga Durga team dated : 23-11-2021.

Lecturer in Physics
SGA GDC
YELLAMANCHILI

Principal
S.G.A Govt. Degree College
YELLAMANCHILI - 531 055
Virekhatnam District



S.G.A.GOVERNMENT DEGREE COLLEGE

(Re-accredited by NAAC with 'A' Grade, Affiliated to Andhra University)

YELLAMANCHILI - 531055, ANDHRA PRADESH



Student working model on "**PREVENTION OF ACCIDENTS IN HILLY AREAS**" AND "**3D-HOLOGRAM**" Respectively prepared by Krishnaveni team and Uma Devi team

dated :06-12-2021.

Lecturer in Physics
S.G.A. G.D.C
YELLAMANCHILI

Principal
S.G.A Govt. Degree College
YELLAMANCHILI - 531 055
Vizakhapatnam District



S.G.A.GOVERNMENT DEGREE COLLEGE

(Re-accredited by NAAC with 'A' Grade, Affiliated to Andhra University)

YELLAMANCHILI - 531055, ANDHRA PRADESH



Student working models on **“RAIN DETECTOR” AND “HYDRALIC JCB”** Respectively are prepared by Lakshmi team and Leela Lakshmi team dated : 10-12-2021.

Lecturer in Physics
SGA GDC
YELLAMANCHILI

Principal
S.G.A Govt. Degree College
YELLAMANCHILI - 531 055
Vizakhapatnam District



S.G.A.GOVERNMENT DEGREE COLLEGE

(Re-accredited by NAAC with 'A' Grade, Affiliated to Andhra University)

YELLAMANCHILI - 531055, ANDHRA PRADESH



Project Name

Water Overflow Alarm Indicator



Project Guided by Project done by Sri P.S.Jaggarao 1. M. Varma (II-B.Sc- MPCs)

HOD Department of Physics. 2. M. Sandeep (II-B.Sc- MPCs)

Sri K .

Venkanna 3. D. Prasad (II-B.Sc- MPCs) Lecturer in Physics



Water Overflow Alarm Indicator

Aim:Setting up of water level alarm indicator in our college campus at two places to minimize wastage of water and power

Introduction

We the group of three members are engaged to do Water Level over flow Indicator by Department of Physics. We have implemented this at two overhead water tanks in our college campus. Nowadays everybody has overhead tank at their homes. But everyone who has a water tank top of their homes knows the kind of problems that they face. Initially there is no system to track the water in the tank. Second problem is that when their water pump is started they have no idea when it gets filled up. Sometimes there are situations where the pump keeps on *pumping water to the tank* and the water starts *spilling out from the tank*. There is **wastage of energy** as well as **wastage of water**.

Components Required:

Buzzer, wire, nails...

Working

Now as the water starts to rise the sensors start to get in contact with the water and the transistors are activated and there is a flow of current in the transistors making the LED's light up. Here in between the transistor and the LED there is a current limiting resistor 470 ohms, the job of the resistor is to check that the LED does not get over voltage and destroy the LED. The transistor is biased by a 470K resistor with the ground and the sensing part is taken from the collector with a 33 ohms resistor going directly to the tank.

The Buzzer Part

Here you can add any of the normal buzzers that are readily available in the market and if it is not then you can make yourself with a simple 555 IC. We are giving a small circuit diagram, it is really simple to make it with a minimum components. It is a simple audio oscillator. We have also provided a circuit diagram.

The Power Supply

This section contains a transformer converting the mains voltage 220V brings down to 9V. There is a bridge rectifier containing 4 diodes and making the Alternating current to Direct Current. After the filtering the voltage is then directly fed to the voltage regulator (7805) with a filtering capacitor. From the regulator IC the output voltage is then again filtered with a capacitor and is fed to the circuit. This comprises the power supply of the device.

Outcomes

We minimized the water wastage and power wastage in our campus

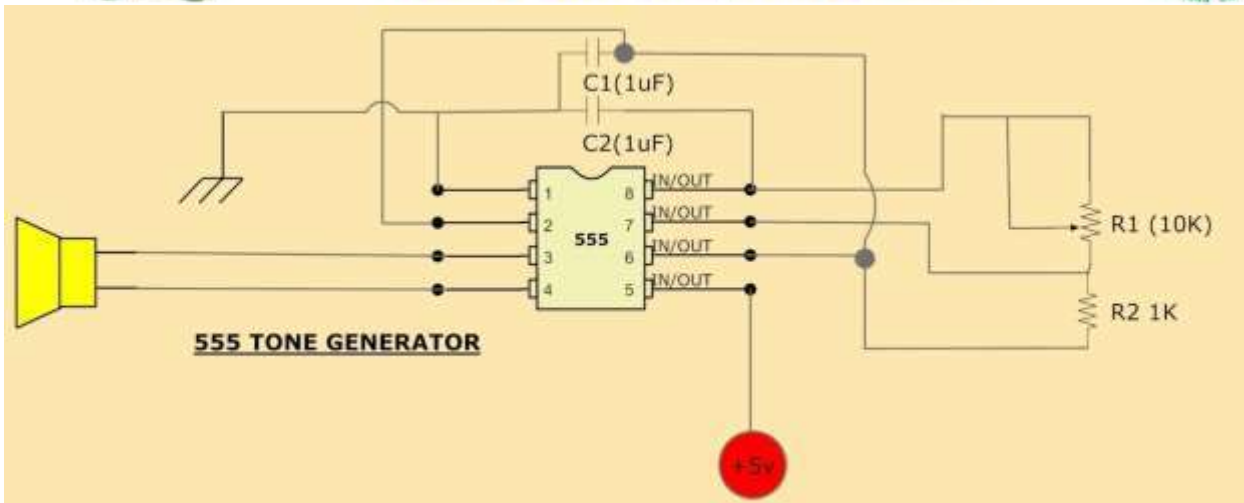

Above two figures shows circuit diagram of Buzzer indicator and tanks for which our project is implemented.



S.G.A.GOVERNMENT DEGREE COLLEGE

(Re-accredited by NAAC with 'A' Grade, Affiliated to Andhra University)

YELLAMANCHILI - 531055, ANDHRA PRADESH



Project implemented at overhead tanks located at top of principal chamber and top of seminar hall by our team members.



S.G.A.GOVERNMENT DEGREE COLLEGE

(Re-accredited by NAAC with 'A' Grade, Affiliated to Andhra University)

YELLAMANCHILI - 531055, ANDHRA PRADESH



ONE DAY TRAINING ON ICT SKILLS TO NON-TEACHINGSTAFF

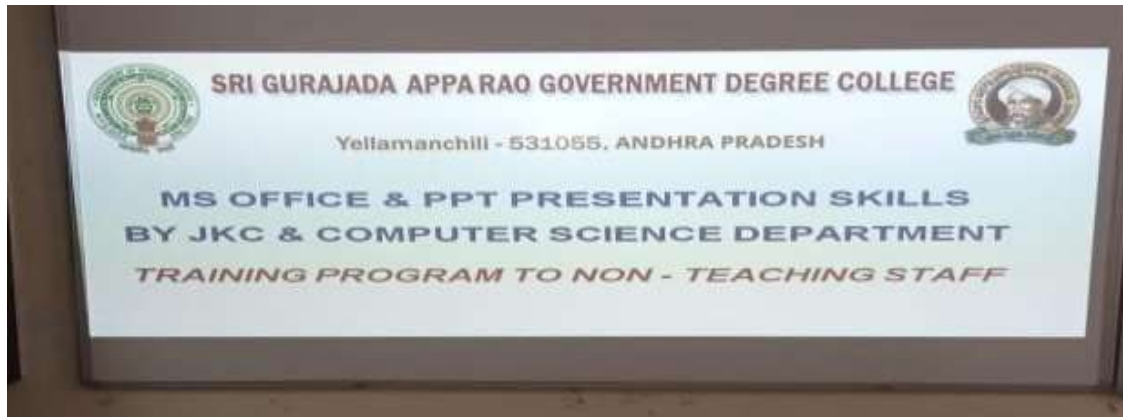

One Day Training on ICT skills to Non-Teaching Staff by JKC and Department of Computer Science Dated 18-10-2021.



S.G.A. GOVERNMENT DEGREE COLLEGE

(Re-accredited by NAAC with 'A' Grade, Affiliated to Andhra University)

YELLAMANCHILI - 531055, ANDHRA PRADESH



Initiatives OF ENGLISH LANGUAGE LAB

About English Language & Lab

The English Language Lab was established in our college during the academic year . It was inaugurated on

India is following three language formulae as recommended by the Kothari Commission wide the National Education policy in 1968. In these three language formulae the national, international and regional interests were taken into consideration. The constitution of India recognized Hindi as national language, English as second language or third depending on the need and the state/regional language as third language. In Andhra Pradesh these three language formulae observed with the spirit of the constitution and in school and college education, up to degree, English language made as compulsory. As the importance of language grows in seeking for further education, employment opportunities, communication skills and soft skills the government of Andhra Pradesh introduced English Language Labs at degree level. The motto of these labs is to enhance English knowledge giving priority to the language skills, i.e., Listening, Speaking, Reading and Writing.

English language gained momentum after globalization, world trade and the revolutionary change in Information and communication technology which synchronized the world into a global village. The speed of communication in various modes like mass media, twitter, what's app, google mail, etc., came into use. The present direct or face-to-face education system replaced to some extent by blended learning which is less efforted in cost and time. On line education, evaluation and assessment made easy in this ICT. Because of this, the fear factor, shyness to rise a doubt and answer a question even though the stakeholder knew the answer will be addressed through language lab up to the attainment of confidence to face the above problems. The stakeholders will develop a self-consciousness about their mistakes and they themselves rectify as it is a self-faced learning. Another facility is. they can repeatedly use this lab for excellence unlike in the live class room. To reach global standards, up-dating their knowledge, it is essential to give such knowledge to the students through English Language Labs.

The word lab is usually associated with science and technology. So, how an English lab works and what is its practicality in learning or acquisition of language may arise some doubts in everyone's mind. Here is the answer. Any language is skill based. In any language the common skills are listening, speaking, reading and writing. In these skills two are active skills and two are passive skills. Listening and reading are passive and speaking and writing are active skills. In English language lab, the ability of hearing, using a headset will be tested. It also helps to know the conceptualization or understanding and grasping the content. Prompting, utterance, modulation, pitch, rising and falling tones could be possible through this lab. Through voice recorder the stakeholders could rectify their pronunciation errors.

Lab equipment:

The lab is equipped with 30 table top computers partitioned with glass compartments. Each computer has enough configuration to suit the needs of the students. Apart from hardware the software relating to other necessities equipped with. Head phones are provided. In software, communication skills CD's, spoken language CD's, dictionaries also provided. Good seating arrangements with a revolving chair are provided. Keyboard and mouses, monitors, CPU's, power cables with UPIs also provided. A public addressing system, overhead projector, 24 x 7 power supporting batteries for back-up service, books on English language and grammar are provided. Altogether a good ambience of learning English language was created in this English language lab.

Objectives of the lab:

- To provide good pronunciation skills
- To make the stakeholders fluent in spoken English
- To improve good communication
- To improve employment skills
- To improve various mailing systems like google mail, what's app, twitter etc.,



S.G.A. GOVERNMENT DEGREE COLLEGE

(Re-accredited by NAAC with 'A' Grade, Affiliated to Andhra University)

YELLAMANCHILI - 531055, ANDHRA PRADESH



- To develop personality skills
- To improve interview skills
- To improve net-etiquette skills
- To improve reading (a loud), and reciting skills
- To improve addressing, public speech, oratory skills
- To improve presentation skills
- To improve drafting skills
- To improve news writing, document writing, pleading, noticing, mongering skills.
- To improve good listening (Active listening) skills
- To improve writing skills.

Lab Activities

1. Dictation to every batch.
2. Spelling check
3. Pronunciation
4. Hearing test
5. Online grammar test
6. YouTube videos
7. Running commentary (while the video is playing)
8. Reading aloud (comprehension passages)
9. Recitation of poems
10. Phonetics
11. E-mail and Hot-mails
12. C.V's & cover letter practice
13. Monologues
14. Dialogues
15. One-act plays
16. Group & Team works
17. Role play
18. Information giving & taking techniques
19. Debates
20. Elocutions



S.G.A. GOVERNMENT DEGREE COLLEGE

(Re-accredited by NAAC with 'A' Grade, Affiliated to Andhra University)

YELLAMANCHILI - 531055, ANDHRA PRADESH



Our college English language lab





S.G.A. GOVERNMENT DEGREE COLLEGE

(Re-accredited by NAAC with 'A' Grade, Affiliated to Andhra University)

YELLAMANCHILI - 531055, ANDHRA PRADESH



Conducting hearing test to the students with the help of head phones





S.G.A. GOVERNMENT DEGREE COLLEGE

(Re-accredited by NAAC with 'A' Grade, Affiliated to Andhra University)

YELLAMANCHILI - 531055, ANDHRA PRADESH



LANGAUGE AND C COMMUNICATION SKILLS

Dated: 08/2/2022

To
The Principal,
S.G.A., Govt. Degree College,
Yelamanchili,
Anakapalli Dist.,

Respected Sir

Sub: Request –Permission—Communication skills and soft skills for a new batch—regarding

&&&

The department of English is pleased to inform you that we initiated a programme to improve students communication and soft skills for their individual development. For this the batches were selected from students and listed here with consisting of II B.A., and II B. Sc students. Please permit this batch to conduct classes in zero hours. This is for your kind information and record to take further action.

Thanking you Sir,

Yours sincerely

(G. SATYANARAYANA)



S.G.A. GOVERNMENT DEGREE COLLEGE

(Re-accredited by NAAC with 'A' Grade, Affiliated to Andhra University)

YELLAMANCHILI - 531055, ANDHRA PRADESH



DEPARTMENT OF ENGLISH

CIRCULAR

Dated: 9/02/2022

This is to inform the students of second year that the department of English is going to conduct a soft skills programme in English spoken English as well as employment skills. It includes telephone etiquette, interview skills, behavioural skill, interactive skills etc., Henceforth, with the instructions of the Principal of our college; the department of English is pleased to conduct the programme at zero hours of the college. Whoever interested in this programme, may consult the HOD of the department or Sri K. Premasagar to register their names



G.Satynarayana lecturer in English delivering his lecture on soft skills



S.G.A. GOVERNMENT DEGREE COLLEGE

(Re-accredited by NAAC with 'A' Grade, Affiliated to Andhra University)

YELLAMANCHILI - 531055, ANDHRA PRADESH



LIST OF STUDENTS ENROLLED

S.No.	Name of the Student	Hall ticket no.	Group
1	A.KONDA BABU	120135401001	II BA
2	B.GOURI DEVI	120135401002	II BA
3	C.HARSHAVARDHAN	120135401003	II BA
4	D.AV.V.S.N.MURTHY	120135401004	II BA
5	D.PAVAN KUMAR	12013540100	II BA
6	E.SARAWATHI	120135401007	II BA
7	K.SRINIVASA RAO	120135401008	II BA
8	K.MOHAN	190135401009	II BA
9	K.DURGA PRASAD	120135401011	II BA
10	K.APPALA RAJU	120135401013	II BA
11	P.MUNNA	120135401015	II BA
12	P.DURGA PRASAD	120135401016	II BA
13	R.VENKALAKSHMI	120135401017	II BA
14	R.GANESH	120135401018	II BA
15	ARJILLIAMMAJI	720135405071	II BSC
16	CHITTIDEVIKA	720135405072	II BSC
17	DEVARADIVYA	720135405073	II BSC
18	ERIGILAVANDANA	720135405074	II BSC
19	GORINTAMEENAKSHI	720135405075	II BSC
20	GUDDATIUSHARANI	720135405076	II BSC
21	KALLAPUSHPALAKSHMI	720135405077	II BSC
22	KANTAMREDDYASHA	720135405078	II BSC
23	KARRIVISWANADHAM	720135405079	II BSC
24	KOLANTIANUSHA	720135405080	II BSC
25	M.BHAGYALAKSHMI	720135405081	II BSC
26	MOGILIBHARGAVI	720135405082	II BSC
27	MOORARATNAKUMARI	720135405083	II BSC
28	OMMIKUMARI	720135405084	II BSC
29	PADALATRIVENI	720135405085	II BSC
30	PEDAPUDILATHA	720135405086	II BSC
31	PUDIKAHYA	720135405087	II BSC
32	RAJESWARIYANDA	720135405088	II BSC
33	RANGALANAVYA	720135405089	II BSC
34	REDDIDAIVAMADHURI	720135405090	II BSC
35	R.VENKATALAKSHMI	720135405091	II BSC
36	SHAIKRAHIMTUNEESEA	720135405092	II BSC
37	SONYGUDALA	720135405093	II BSC
38	TELUSURYALAKSHMI	720135405094	II BSC
39	TH. MOUNIKADEVI	720135405095	II BSC
40	AMALAKANTISATYA	720135405070	I BSC



S.G.A. GOVERNMENT DEGREE COLLEGE

(Re-accredited by NAAC with 'A' Grade, Affiliated to Andhra University)

YELLAMANCHILI - 531055, ANDHRA PRADESH



Testing and listening pronunciation of the students



S.G.A. GOVERNMENT DEGREE COLLEGE

(Re-accredited by NAAC with 'A' Grade, Affiliated to Andhra University)

YELLAMANCHILI - 531055, ANDHRA PRADESH



SGAGovt.DegreeCollege,Yellamanchili

Department of Botany

IIICBZ,SEM-VI

Student seminars, 2021-22



Name: G.Sandhya Topic: Applications of Genetic Engineering

Date: 22-03-2022



Name: R.Lavanya Topic: Somatic Embryos and Artificial Seeds

Date: 22-03-2022



S.G.A. GOVERNMENT DEGREE COLLEGE

(Re-accredited by NAAC with 'A' Grade, Affiliated to Andhra University)

YELLAMANCHILI - 531055, ANDHRA PRADESH



SGA Govt. Degree
College, Yellamanchili Department of Botany

IICBZ, SEM-III Student Seminars, 2021-22



Name: K. Viswanth

Topic: Types of Vascular Bundles

Date: 25-03-2022



Name: Daiva Madhuri

Topic: T. Sof Anther

Date: 25-03-2022



Name: G. Navya Topic: Hotspots in India

Date: 25-03-2022



S.G.A. GOVERNMENT DEGREE COLLEGE

(Re-accredited by NAAC with 'A' Grade, Affiliated to Andhra University)

YELLAMANCHILI - 531055, ANDHRA PRADESH



SGA Govt. Degree
College, Yellamanchili Department of Botany

IICBZ, SEM-III Student Seminars, 2021-22



Name: CH. Devika Topic: Types of Vascular Bundles

Date: 28-03-2022



Name: G. Meenakshi Topic: Ecological Pyramids

Date: 28-03-2022



Name: G. Pushpa Lakshmi Topic: Food Chain

Date: 28-03-2022



S.G.A. GOVERNMENT DEGREE COLLEGE

(Re-accredited by NAAC with 'A' Grade, Affiliated to Andhra University)

YELLAMANCHILI - 531055, ANDHRA PRADESH



SGA Govt. Degree
College, Yellamanchili Department of Botany

IIICBZ, SEM-VI

Student Seminars, 2021-22



Name: M. Sravani Topic: Embryo Culture

Date: 29-03-2022



Name: K. P. S. Chandrika Topic: Totipotency and Tissue Culture

Date: 29-03-2022



Name: K. Aruna Topic: Cloning Vectors

Date: 29-03-2022



S.G.A. GOVERNMENT DEGREE COLLEGE

(Re-accredited by NAAC with 'A' Grade, Affiliated to Andhra University)

YELLAMANCHILI - 531055, ANDHRA PRADESH



SGA Govt. Degree College,
Yellamanchili Department of Botany

IIICBZ, SEM-VI

Student seminars, 2021-22



Name: G.Kavya

Topic: Principles of Plant Tissue Culture

Date: 06-04-2022



Name: J.Jyothi

Topic: Ti-Plasmid

Date: 06-04-2022



Name: P.Bharathi

Topic: Transgenic Plants

Date: 06-04-2022



S.G.A. GOVERNMENT DEGREE COLLEGE

(Re-accredited by NAAC with 'A' Grade, Affiliated to Andhra University)

YELLAMANCHILI - 531055, ANDHRA PRADESH



SGA Govt. Degree College,
Yellamanchili Department of Botany
IICBZ, SEM-III Student seminars, 2021-22



Name:P.Kavya Topic:Hydrosere

Date:12-04-2022



Name:D.Ammaji Topic: Threats to Biodiversity

Date:12-04-2022



Name:O.Kumari Topic: Impact of Temperature on Plants

Date:12-04-2022



S.G.A. GOVERNMENT DEGREE COLLEGE

(Re-accredited by NAAC with 'A' Grade, Affiliated to Andhra University)

YELLAMANCHILI - 531055, ANDHRA PRADESH



SGA Govt. Degree College,
Yellamanchili Department of Botany

IICBZ, SEM-III Student seminars, 2021-22



Name: M. Bhargavi

Topic: Types of Vascular Bundles

Date: 12-04-2022



Name: G. Usha Rani

Topic: Xerophytes

Date: 12-04-2022



S.G.A.GOVERNMENT DEGREE COLLEGE

(Re-accredited by NAAC with 'A' Grade, Affiliated to Andhra University)

YELLAMANCHILI - 531055, ANDHRA PRADESH



Circular

Date: 16-12-2021

This is to inform you that all the students and all the teaching staff that our college is going to organise Yoga Class by Yoga CO-Ordinator B.ChandraMouli in our Seminar Hall at 11 AM. You all are requested to attend with white uniform or any convenient dress and if possible please bring a yoga mat to perform yoga asanas and other related kriyas.

Your presence is highly demanded on this occasion as the class work suspended.

Programme CO-Ordinator,
Yoga and Physical Fitness

Principal
S.G.A. Govt. Degree College
Yellamanchili-531 055
Anakapalli District. (A.P.)



S.G.A.GOVERNMENT DEGREE COLLEGE

(Re-accredited by NAAC with 'A' Grade, Affiliated to Andhra University)

YELLAMANCHILI - 531055, ANDHRA PRADESH



Extension activity, 2021-22

Activity: Practice Session of Yoga and Meditation Date: 16-12-2021



Dr. B. Chandramouli, Lecturer in Botany Explaining the importance of Yoga & Meditation



Staff and Students in the practice session of Meditation



S.G.A.GOVERNMENT DEGREE COLLEGE

(Re-accredited by NAAC with 'A' Grade, Affiliated to Andhra University)

YELLAMANCHILI - 531055, ANDHRA PRADESH



LIST OF STUDENTS ENROLLED AND PARTICIPATED IN YOGA AND MEDITATION 2020-21



S.G.A.GOVERNMENT DEGREE COLLEGE

(Re-accredited by NAAC with 'A' Grade, Affiliated to Andhra University)

YELLAMANCHILI - 531055, ANDHRA PRADESH



Staff and Students in the practice session of Meditation

10-21

LIST OF STUDENTS ENROLLED AND PARTICIPATED IN YOGA AND MEDITATION 2020-21

S. No	Name of the Student	Group	Signature of the student
1	Arjilli Ammaji	II BSC	A. Ammaji
2	Chitti Devika	II BSC	Ch. Devika
3	Devara Divya	II BSC	D. Divya
4	Erigila Vandana	II BSC	C. Vandana
5	Gorinta Meenakshi	II BSC	G. Meenakshi
6	Guddati Usha Rani	II BSC	G. Usha Rani
7	Kalla Pushpalakshmi	II BSC	K. Pushpa Lakshmi
8	Kantamreddy Asha	II BSC	K. Asha
9	Karri Viswanadham	II BSC	K. Viswanadham
10	Kolanti Anusha	II BSC	K. Anusha
11	M. Bhagyalakshmi	II BSC	M. Bhagy Lakshmi
12	Mogili Bhargavi	II BSC	M. Bhargavi
13	Moora Ratna Kumari	II BSC	M. Ratna Kumari
14	Ommi Kumari	II BSC	O. Kumari
15	Padala Triveni	II BSC	P. Triveni
16	Pedapudi Latha	II BSC	P. Latha
18	Pudi Kavya	II BSC	P. Kavya
19	Rajeswari Yanda	II BSC	Y. Rajeswari
20	Rangala Navya	II BSC	R. Navya
21	Reddi Daiva Madhuri	II BSC	R. Daiva madhuri
22	R. Venkatalakshmi	II BSC	R. Venkata Lakshmi
23	Shaik Rahim Tuneesha	II BSC	S. Rahim Tuneesha
24	Sony Gudala	II BSC	S. Sony
25	Telu Surya Lakshmi	II BSC	T. Surya lakshmi
26	Th. Mounika Devi	II BSC	T. Mounika Devi
27	B. Sukanya	I BSC	B. Sukanya
28	B. Nookaratnam	I BSC	B. Nookaratnam
29	B. Tejasvi	I BSC	B. Tejasvi
30	B. Leela Praveena	I BSC	B. Leela praveena
31	B. Divya Krupa	I BSC	B. Divya Krupa
32	B. Lavanya	I BSC	B. Lavanya
33	Ch. Swathi	I BSC	Ch. Swathi
34	Ch. Mokshasri	I BSC	Ch. Mokshasri
35	D. Sivaji	I BSC	D. Sivaji
36	D. Nissi Alekhya	I BSC	D. Nissi Alekhya



S.G.A.GOVERNMENT DEGREE COLLEGE

(Re-accredited by NAAC with 'A' Grade, Affiliated to Andhra University)

VELLAMANCHILI - 531055, ANDHRA PRADESH



S.G.A.GOVERNMENT DEGREE COLLEGE

(Re-accredited by NAAC with 'A' Grade, Affiliated to Andhra University)

VELLAMANCHILI - 531055, ANDHRA PRADESH



20-21

37	E.Hema Varaha Durga	I BSC	E. Hema Varaha Durga
38	G.Emmi Vinolisi	I BSC	G. Emmi Vinolisi
39	G.Dhikshitha	I BSC	G. Dhikshitha
40	G.Kirankumar	I BSC	G. Kirankumar
41	G.Rani	I BSC	G. Rani
42	J.Sirdhu	I BSC	J. Sirdhu
43	K. Vasantha	I BSC	K. Vasantha
44	K.Lakshmi	I BSC	K. Lakshmi
45	K.Loriya	I BSC	K. Loriya
46	K.Mounika	I BSC	K. Mounika
47	K.Kumari Sreelakshmi	I BSC	K. Kumari Sreelakshmi
48	Kdivya	I BSC	K. Divya
49	L. Yasawini	I BSC	L. Yasawini
50	M.Devi	I BSC	M. Devi
51	M.Nagalakshmi	I BSC	M. Nagalakshmi
52	M.Pushpalatha	I BSC	M. Pushpalatha
53	M.Sravani Sai	I BSC	M. Sravani Sai
54	M. Siva Sravani	I BSC	M. Siva Sravani
55	M. Navitha	I BSC	M. Navitha
56	P.Pavani	I BSC	P. Pavani
57	P.Ratna Malathi Naveena	I BSC	P. Ratna Malathi Naveena
58	S.Divya	I BSC	S. Divya
59	T.Lohitha Sri	I BSC	T. Lohitha Sri
60	V.Sai	I BSC	V. Sai
61	V.Vineel	I BSC	V. Vineel
62	V.Jayasri	I BSC	V. Jayasri
63	V.Tulasi	I BSC	V. Tulasi
64	V.Uma Maheswari	I BSC	V. Uma Maheswari
65	N.Lakshmi Ganesh	II Bcom	N. Lakshmi Ganesh
66	P.Ganesh	II Bcom	P. Ganesh
67	P.Suryakala	II Bcom	P. Suryakala
68	P.Bhavani	II Bcom	P. Bhavani
69	P.Preetham	II Bcom	P. Preetham
70	P.Sukanya	II Bcom	P. Sukanya
71	P.Venkata Lakshmi	II Bcom	P. Venkata Lakshmi
73	R.Varalakshmi	II Bcom	R. Varalakshmi
74	S.Hymavathi	II Bcom	S. Hymavathi
75	S.Yakub Raju	II Bcom	S. Yakub Raju
76	T.Leela	II Bcom	T. Leela
77	U.Naveen	II Bcom	U. Naveen
78	U.Mayuri	II Bcom	U. Mayuri
79	G.Ganesh	III BSC	G. Ganesh
80	G.Sirisha Rani	III BSC	G. Sirisha Rani
81	G.Hari Babu	III BSC	G. Hari Babu
82	K.Mahesh	III BSC	K. Mahesh
83	K.Appalaraju	III BSC	K. Appalaraju
84	K. Chinnari	III BSC	K. Chinnari



International Yoga Day celebrations were organised in

SGA GDC Yellamanchili on 21-06-2022

The Programme Report:

Yoga day celebrated in a great befitting manner. Our college has two yoga diploma holders from Andhra University one is our college Physical Director Dr.Polireddy and the other Sri G. Satyanarayana, lecturer in English. On this day all the students were gathered in college seminar hall along with other teaching staff. Our Principal Dr. Chandrasekhar presided over the gathering and he addressed the students. In his speech he remarked the importance of Yoga and its importance, how it came into prominence. There after teaching staff also spoke about it. Mr. Satyanarayana lecturer in English acted as resource person and Dr. B. Chandramouli demonstrated acts of Yoga like Asanas, kriyas, Bhandanas.

Mr. Satyanarayana explained the following:

- | | |
|---------------|-----------------|
| 1. Yamas | : abstinences |
| 2. Niyama | : Observances |
| 3. Asana | : Postures |
| 4. Pranayama | : Breathing |
| 5. Prathahara | : Withdrawal |
| 6. Dharana | : Concentration |
| 7. Dhyna | : Meditation |
| 8. Samadhi | : Absorption |

After this explanation, he directed the pupil to do some warm-ups followed by postures in three states i.e., standing, sitting and lie-down.

In standing postures Tada asana, TiryakaTadaana, Kati Chakrasana, Hasta Utthanasana, AkaranaDhanrasana, Tiryakakatichakrasana, Meru Prishthasana, Utthansana, Trikonasana etc.,

In Sitting postures: Patchimothasana, Padmasana, Vajrasana, Kukkutasana, Ardhamathyasana, etc.,

Lay-down postures: Savasana, Bhujangasana, Halasana, Sarvangasana, Chakrasana, Sarpasana,

Apart from the above some balancing asanas also demonstrated and performed by the students.

After that Pranayama, the breathing exercise was performed and all the students paid interest as they learned through the description given by the resource person that it will help them in their studies to improve concentration.

The resource person G. Satyanarayana appreciated one of the female student who performed well in all asanas and awarded prize money. He also appreciated Dr. Chandramouli for his commitment in performing and guiding the students.



International Yoga Day Celebrations

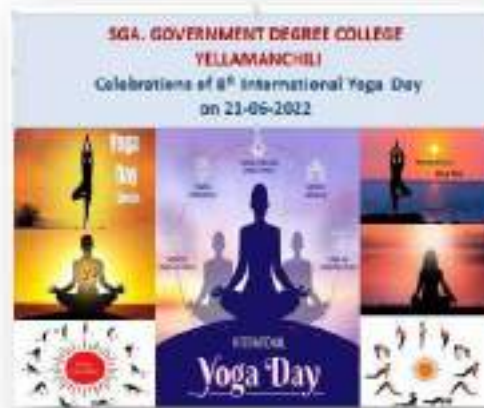

International Yoga Day Celebrations were held at seminar hall on 21-06-2022. Dr P Chandrasekhar along with staff and students were actively participated. Together all were practiced some popular yoga asanas.



**Dr B Chandramouli, Lecturer in Botany has demonstrated
the various yoga asanas to the students during
International Yoga Day Celebrations**



Departmental Activities



S.G.A.GOVERNMENT DEGREE COLLEGE

(Re-accredited by NAAC with 'A' Grade, Affiliated to Andhra University)

VELLAMANCHILI - 531055, ANDHRA PRADESH



LIST OF STUDENTS ENROLLED AND PARTICIPATED IN YOGA AND MEDITATION 2021-22



S.G.A.GOVERNMENT DEGREE COLLEGE

(Re-accredited by NAAC with 'A' Grade, Affiliated to Andhra University)

VELLAMANCHILI - 531055, ANDHRA PRADESH



LIST OF STUDENTS ENROLLED AND PARTICIPATED IN YOGA AND MEDITATION 2021-22

S. No	Name of the Student	Group	Signature of the student
1	Arjilli Amraji	II BSC	A. Amraji
2	Chitti Devika	II BSC	ch. Devika
3	Devara Divya	II BSC	Devara Divya.
4	Erigila Vandana	II BSC	E. Vandana
5	Gorinta Meenakshi	II BSC	Or. Meenakshi
6	Guddati Usha Rani	II BSC	G. Usha Rani
7	Kalla Pushpalakshmi	II BSC	K. pushpa lakshmi.
8	Kantamreddy Asha	II BSC	K. Asha
9	Karri Viswanadham	II BSC	K. Viswanadham.
10	Kolanti Anusha	II BSC	K. Anusha
11	M. Bhagyalakshmi	II BSC	M. Bhagya Lakshmi
12	Mogili Bhargavi	II BSC	M. Bhargavi
13	Moora Ratna Kumari	II BSC	M. Ratna Kumari
14	Omni Kumari	II BSC	O. Kumari
15	Padala Triveni	II BSC	P. Triveni
16	Pedapudi Latha	II BSC	P. Latha
18	Pudi Kavya	II BSC	P. Kavya
19	Rajeswari Yanda	II BSC	Y. Rajeswari
20	Rangala Navya	II BSC	R. Navya
21	Reddi Daiva Madhuri	II BSC	R. Daiva madhuri
22	R. Venkatalakshmi	II BSC	R. Venkatalakshmi
23	Shaik Rahim Tunesha	II BSC	St. R. Tunesha
24	Sony Gudala	II BSC	Sony. Gudala
25	Telu Surya Lakshmi	II BSC	T. Surya lakshmi
26	Th. Mounika Devi	II BSC	Th. Mounika Devi
27	B. Sukanya	I BSC	B. Sukanya
28	B. Nookaratnam	I BSC	B. Nookaratnam
29	B. Tejasvi	I BSC	B. Tejasvi
30	B. Leela Praveena	I BSC	B. Leela Praveena
31	B. Divya Krupa	I BSC	B. Divya Krupa
32	B. Lavanya	I BSC	B. Lavanya
33	Ch. Swathi	I BSC	Ch. Swathi
34	Ch. Mokshasri	I BSC	Ch. Mokshasri
35	D. Sivaji	I BSC	D. Sivaji
36	D. Nissi Alekhya	I BSC	D. Nissi Alekhya
37	E. Hema Varaha Durga	I BSC	E. Hema Varaha Durga



S.G.A.GOVERNMENT DEGREE COLLEGE

(Re-accredited by NAAC with 'A' Grade, Affiliated to Andhra University)

YELLAMANCHILI - 531055, ANDHRA PRADESH



S.G.A.GOVERNMENT DEGREE COLLEGE

(Re-accredited by NAAC with 'A' Grade, Affiliated to Andhra University)

YELLAMANCHILI - 531055, ANDHRA PRADESH



21-22

38	G.Emmi Vinolini	I BSC	G: Emmivinalini
39	G.Dhikshitha	I BSC	G: Kifan Kanaad
40	G.Kirankumar	I BSC	G: Rami
41	G.Rani	I BSC	G: Rami
42	J.Sindhu	I BSC	K: Valantha
43	K. Vasantha	I BSC	K: Valantha
44	K.Lakshmi	I BSC	K: Lakshmi
45	K.Loriya	I BSC	K: Loriya
46	K.Mounika	I BSC	K: Mounika
47	K.Kumari Sreelakshmi	I BSC	K: K. S. Lakshmi
48	Kdivya	I BSC	K: Divya
49	L.Yasawini	I BSC	L: Yasawini
50	M.Devi	I BSC	M: Devi
51	M.Nagalakshmi	I BSC	M: Nagalakshmi
52	M.Pushpalatha	I BSC	M: Pushpalatha
53	M.Sravani Sai	I BSC	M: Sravani Sai
54	M. Siva Sravani	I BSC	M: Siva Sravani
55	M. Navitha	I BSC	M: Siva Sravani
56	P.Pavani	I BSC	P: Pavani
57	P.Ratna Malathi Naveena	I BSC	P: R. M. Naveena
58	S.Divya	I BSC	S: Divya
59	T.Lohitha Sri	I BSC	T: Lohitha Sri
60	V.Sai	I BSC	V: Sai
61	V.Vineel	I BSC	V: Vineel
62	V.Jayasri	I BSC	V: Jayasri
63	V.Tulasi	I BSC	V: Tulasi
64	V.Uma Maheswari	I BSC	V: Uma Maheswari
65	N.Lakshmi Ganesh	II BCOM	N: Lakshmi Ganesh
66	P.Ganesh	II BCOM	P: Ganesh
67	P.Suryakala	II BCOM	P: Suryakala
68	P.Bhavani	II BCOM	P: Bhavani
69	P.Preetham	II BCOM	P: Preetham
70	P.Sukanya	II BCOM	P: Sukanya
71	P.Venkata Lakshmi	II BCOM	P: Venkata Lakshmi
73	R.Varalakshmi	II BCOM	R: Varalakshmi
74	S.Hymavathi	II BCOM	S: Hymavathi
75	S.Yakub Raju	II BCOM	S: Yakub Raju
76	T.Leela	II BCOM	T: Leela
77	U.Naveen	II BCOM	U: Naveen
78	U.Mayuri	II BCOM	U: Mayuri
79	G.Ganesh	III BSC	G: Ganesh
80	G.Sirisha rani	III BSC	G: Sirisha Rani
81	G.hari babu	III BSC	G: Hari Babu
82	K.Mahesh	III BSC	K: Mahesh
83	K.Appalaraju	III BSC	K: Appalaraju
84	K. Chinnari	III BSC	K: Chinnari
85	K.Prasadu	III BSC	K: Prasadu



S.G.A.GOVERNMENT DEGREE COLLEGE

(Re-accredited by NAAC with 'A' Grade, Affiliated to Andhra University)

VELLAMANCHILI - 531055, ANDHRA PRADESH



S.G.A.GOVERNMENT DEGREE COLLEGE

(Re-accredited by NAAC with 'A' Grade, Affiliated to Andhra University)

VELLAMANCHILI - 531055, ANDHRA PRADESH



28-11

85	K.Prasadu	III BSC	K. prasadu
86	K.Poornasai	III BSC	K. poornasai
87	K.Anitha	III BSC	K. Anitha
88	K.S.S. Shanker	III BSC	K. koothik
89	K.Karthik	III BSC	K. Karthik
90	K.Vasalakshi	III BSC	K. Vasalakshi
91	K.Suryamani	III BSC	K. Surya mani
92	K.Syamala	III BSC	K. Syamala
93	M.Kantham	III BSC	m. kantham
94	M.Sujatha	III BSC	m. Sujatha
95	N.Nookesh	III BSC	N. Nookesh
96	N.Anuradha	III BSC	N. Anuradha
97	P.Madhava	III BSC	P madhava
98	P.Narasinga Rao	III BSC	P. narasingh rao
99	P.Gangabhavani	III BSC	P. Ganga Bhavani
100	P.Priyanka	III BSC	P Priyanka
101	S.Vijay Lakshmi	III BSC	S. vijay lakshmi
102	S. Laxmi Devi	III BSC	S. laxmi devi
103	S.Swetha Rani	III BSC	S. swetha Rani
104	S.L.Shankara Rao	III BSC	S. L. Shankara Rao
105	S.Mangu Sree	III BSC	S. Mangu Sree



S.G.A.GOVERNMENT DEGREE COLLEGE

(Re-accredited by NAAC with 'A' Grade, Affiliated to Andhra University)

YELLAMANCHILI - 531055, ANDHRA PRADESH



CIRCULAR

Date: 19-02-2022

This is to inform all the students that as per the instructions received from the Principal of our college, it is intended to conduct "Yoga" as a regular practice to invoke the idea of good health and wealth in student community. As per his guidelines here in after every third Saturday of the month will be practiced Yoga in our college campus in the seminar hall from 3.00 pm to 5.00 pm. You will be guided by the college resource persons who are authenticated and well practitioners of Yoga. Your attendance will be marked and no permissions will be granted. You have to bring yoga-mat and come to college with white dress. You are instructed to avail this opportunity.

ProgrammeCO-
Ordinator

Yoga and Physical Fitness

Principal
S.G.A. Govt. Degree College
Yellamanchili-531 055
Anakapalli District. (A.P.)



S.G.A.GOVERNMENT DEGREE COLLEGE

(Re-accredited by NAAC with 'A' Grade, Affiliated to Andhra University)

YELLAMANCHILI - 531055, ANDHRA PRADESH



**Department of Economics conducted Yoga and Meditation practice Class
programme conducted on 19-02-2022**





S.G.A.GOVERNMENT DEGREE COLLEGE

(Re-accredited by NAAC with 'A' Grade, Affiliated to Andhra University)

YELLAMANCHILI - 531055, ANDHRA PRADESH



LIST OF STUDENTS ENROLLED AND PARTICIPATED IN YOGA AND MEDITATION 2018-19



S.G.A.GOVERNMENT DEGREE COLLEGE

(Re-accredited by NAAC with 'A' Grade, Affiliated to Andhra University)

YELLAMANCHILI - 531055, ANDHRA PRADESH



LIST OF STUDENTS ENROLLED AND PARTICIPATED IN YOGA AND MEDITATION 2018-19

21-22

S. No	Name of the Student	Group	Signature of the student
1	B.Gouri Devi	II BA	B. Gouri Devi
2	C.Harshavardhan	II BA	C. Harshavardhan
3	D.Av.V.S.N.Murthy	II BA	D. Av. V. S. N. Murthy
4	D.Pavan Kumar	II BA	D. Pavan Kumar
5	E.Sarawathi	II BA	E. Sarawathi
6	K.Srinivasa Rao	II BA	K. Srinivasa Rao
7	K.Mohan	II BA	K. Mohan
8	K.Durga Prasad	II BA	K. Durga Prasad
9	K.Appala Raju	II BA	K. Appala Raju
10	P.Munna	II BA	P. Munna
11	P.Durga Prasad	II BA	P. Durga Prasad
12	R.Venkalakshmi	II BA	R. Venkalakshmi
13	R.Ganesh	II BA	R. Ganesh
14	R.B.Aparna	II BA	R. B. Aparna
15	S.Dhanalakshmi	II BA	S. Dhanalakshmi
16	Y.Rama Teja	II BA	Y. Rama Teja
18	D. Padma	III BA	D. Padma
19	Bangaru Venu	I BA	B. Venu
20	Baithina Kusuma	I BA	B. Kusuma
21	Pendurthi Prasad	I BA	P. Prasad
22	Boddapu Tejarupini	I BA	B. Tejarupini
23	Dondaparthi Nani	I BA	D. Nani
24	G. Vijaya	I BA	G. Vijaya
25	G. Nukaratnam	I BA	G. Nukaratnam
26	Jajala Guna Sekhar	I BA	J. Guna Sekhar
27	M.D.N.S.Suryalaxmi	I BA	M. D. N. S. Suryalaxmi
28	M.Hemanth	I BA	M. Hemanth
29	Mylapalli Srinu	I BA	M. Srinu
30	P. Vinay Kumar	I BA	P. Vinay Kumar



S.G.A.GOVERNMENT DEGREE COLLEGE

(Re-accredited by NAAC with 'A' Grade, Affiliated to Andhra University)

YELLAMANCHILI - 531055, ANDHRA PRADESH



Physical Fitness





S.G.A.GOVERNMENT DEGREE COLLEGE

(Re-accredited by NAAC with 'A' Grade, Affiliated to Andhra University)

YELLAMANCHILI - 531055, ANDHRA PRADESH





S.G.A.GOVERNMENT DEGREE COLLEGE

(Re-accredited by NAAC with 'A' Grade, Affiliated to Andhra University)

YELLAMANCHILI - 531055, ANDHRA PRADESH





S.G.A.GOVERNMENT DEGREE COLLEGE

(Re-accredited by NAAC with 'A' Grade, Affiliated to Andhra University)

YELLAMANCHILI - 531055, ANDHRA PRADESH





S.G.A.GOVERNMENT DEGREE COLLEGE

(Re-accredited by NAAC with 'A' Grade, Affiliated to Andhra University)

YELLAMANCHILI - 531055, ANDHRA PRADESH





S.G.A.GOVERNMENT DEGREE COLLEGE

(Re-accredited by NAAC with 'A' Grade, Affiliated to Andhra University)

YELLAMANCHILI - 531055, ANDHRA PRADESH





S.G.A.GOVERNMENT DEGREE COLLEGE

(Re-accredited by NAAC with 'A' Grade, Affiliated to Andhra University)

YELLAMANCHILI - 531055, ANDHRA PRADESH





S.G.A.GOVERNMENT DEGREE COLLEGE

(Re-accredited by NAAC with 'A' Grade, Affiliated to Andhra University)

YELLAMANCHILI - 531055, ANDHRA PRADESH





S.G.A.GOVERNMENT DEGREE COLLEGE

(Re-accredited by NAAC with 'A' Grade, Affiliated to Andhra University)

YELLAMANCHILI - 531055, ANDHRA PRADESH





S.G.A.GOVERNMENT DEGREE COLLEGE

(Re-accredited by NAAC with 'A' Grade, Affiliated to Andhra University)

YELLAMANCHILI - 531055, ANDHRA PRADESH





S.G.A.GOVERNMENT DEGREE COLLEGE

(Re-accredited by NAAC with 'A' Grade, Affiliated to Andhra University)

YELLAMANCHILI - 531055, ANDHRA PRADESH



Health and Hygiene

SGA, GDC YELLAMANCHILI

**ORGANIZED CORONA VACCINATION DRIVE FOR 1ST YEAR STUDENTS AT
COLLEGE CAMPUS ON 06.01.2022**



**SGA GDC ORGANIZED VACCINATION ON COVID -19.34 STUDENTS WERE TAKEN
VACCINATION ON THAT DAY. NO STUDENT WAS LEFT WITHOUT A VACCINE. FROM THIS
PROGRAMME ENTIRE STUDENTS OF THE COLLEGE HAVE BEEN VACCINATED.**



S.G.A.GOVERNMENT DEGREE COLLEGE

(Re-accredited by NAAC with 'A' Grade, Affiliated to Andhra University)

YELLAMANCHILI - 531055, ANDHRA PRADESH



DEPARTMENT OF COMMERCE, STUDENTS PARTICIPATED IN INTERNATIONAL AIDS DAY ON 01.12.2021





S.G.A.GOVERNMENT DEGREE COLLEGE

(Re-accredited by NAAC with 'A' Grade, Affiliated to Andhra University)

YELLAMANCHILI - 531055, ANDHRA PRADESH





S.G.A.GOVERNMENT DEGREE COLLEGE

(Re-accredited by NAAC with 'A' Grade, Affiliated to Andhra University)

YELLAMANCHILI - 531055, ANDHRA PRADESH



SGA GDC YELLAMACHILI, NSS UNIT AWARENESS MEETING ON OMICRON VIRUS ON 05,01.2022





S.G.A.GOVERNMENT DEGREE COLLEGE

(Re-accredited by NAAC with 'A' Grade, Affiliated to Andhra University)

YELLAMANCHILI - 531055, ANDHRA PRADESH



WE ORGANISED AWARENESS MEETING ON OMICRAN VIRUS AND NSS VOLUNTEERS OF THE SGA DEGREE COLLEGE HAVE BEEN GIVEN AWARENESS ABOUT CORONA DISEASE AND WHAT KIND OF PRECAUTIONS ARE REQUIRED FOR NOT SPREADING THE DISEASE. SRI R. RAMA RAO, LEC IN COMMERCE, SRI V.A. SATYANARAYANA, LEC. IN TELUGU, SRI V.CHITTIBABU, NSS PROGRAMME OFFICER AND SRI M.KISHORE LEC.IN COMMERCE PARTICIPATED IN THIS MEETING.



S.G.A.GOVERNMENT DEGREE COLLEGE

(Re-accredited by NAAC with 'A' Grade, Affiliated to Andhra University)

YELLAMANCHILI - 531055, ANDHRA PRADESH



**DEPARTMENT OF COMMERCE,
STUDENTS PARTICIPATED IN CAMPUS CLEANING ON 26.10.2021**





S.G.A.GOVERNMENT DEGREE COLLEGE

(Re-accredited by NAAC with 'A' Grade, Affiliated to Andhra University)

YELLAMANCHILI - 531055, ANDHRA PRADESH





S.G.A.GOVERNMENT DEGREE COLLEGE

(Re-accredited by NAAC with 'A' Grade, Affiliated to Andhra University)

YELLAMANCHILI - 531055, ANDHRA PRADESH



**DEPARTMENT OF COMMERCE,
STUDENTS PARTICIPATED IN CAMPUS CLEANING ON 07.12.2021**





S.G.A.GOVERNMENT DEGREE COLLEGE

(Re-accredited by NAAC with 'A' Grade, Affiliated to Andhra University)

YELLAMANCHILI - 531055, ANDHRA PRADESH



DEPARTMENT OF PHYSICS

ACTIVITY ON PLASTIC FREE CAMPUS 2021-22



Activity on plastic free campus was conducted in the college campus on 10.02.2022 about 60 students participated in the activity.



S.G.A.GOVERNMENT DEGREE COLLEGE

(Re-accredited by NAAC with 'A' Grade, Affiliated to Andhra University)

YELLAMANCHILI - 531055, ANDHRA PRADESH



Department of Botany

Activity: World Anti Tobacco Day

Group: All Groups of Students

Date: 31-05-2022



Dr. B. Chandramouli, In-Charge of the Dept. of Botany, Dr.V. Padmaja, Lecturer in Botany and Dr.A.ArjunaApparao, Lecturer in Zoology celebrated Anti Tobacco Day on 31-05-2022



S.G.A.GOVERNMENT DEGREE COLLEGE

(Re-accredited by NAAC with 'A' Grade, Affiliated to Andhra University)

YELLAMANCHILI - 531055, ANDHRA PRADESH



Women Empowerment Cell

Activity: World Milk Day

Group: II CBZ

Date: 29-06-2022





S.G.A.GOVERNMENT DEGREE COLLEGE

(Re-accredited by NAAC with 'A' Grade, Affiliated to Andhra University)

YELLAMANCHILI - 531055, ANDHRA PRADESH



**Women Empowerment Cell organised World Milk Day on
29-06-2022**



S.G.A.GOVERNMENT DEGREE COLLEGE

(Re-accredited by NAAC with 'A' Grade, Affiliated to Andhra University)

YELLAMANCHILI - 531055, ANDHRA PRADESH



DEPARTMENT OF COMPUTER SCIENCE

Add -on Course in **WEB DESIGNING** for the academic year 2021-22

SUMMARY REPORT

The department of **Computer Science** has started add - on course on "**web designing**" with 78 students from all final years of sga gdc.

Department of **computer science** conducted 30 classes to complete the syllabus within stipulated time from 14/02/2022 to 03 /03 /20 22. The exams were conducted to registered students for 30 marks and issued certificates to all students.

Web designing is one of the important employment field in present era. There are many opportunities to students in social media and web designing . So department of **computer science** introduced this course for the benefit of students in their future .all the students were presented and gained proper knowledge in **web designing** .

- 1 . Number of students enrolled : 78
2. Number of students completed : 78
3. Classes conducted :30 hours
4. Maximum marks : 30 marks
5. Time : morning and evening 2 hours.

D. Sai charan

Head of Computer Science

P. Chandra Babu

Principal
S.G.A.Govt.Degree College
YELLAMANCHILI - 531 055
Visakhapatnam District.



S.G.A.GOVERNMENT DEGREE COLLEGE

(Re-accredited by N.A.A.E. with 'A' Grade, Affiliated to Andhra University)

VELLAMANCHILI - 534085, ANDHRA PRADESH



DEPARTMENT OF COMPUTER SCIENCE

ADD-ON COURSE IN

"WEB DESIGNING"

CERTIFICATE

This is to certify that Mr./Ku _____ S/o/D/o _____

Regd. No _____ has successfully completed the add-on course in

"WEB DESIGNING" in this college held from _____ to _____.

Head of the Department

The Principal



SRI GURAJADA APPA RAO GOVERNMENT DEGREE COLLEGE



NAAC A GRADE

Annexure -A

We here by confirm that APSSDC sponsored training on Pharma marketing executive Offline classes have been organized to our ESC registered students in our campus, the details of the programme are:

Subject/Course	Pharma marketing executive					
Name of the trainer	Prasanth					
Training Start Date	10-01-2020					
Training Completion Date	09-03-2020					
Duration (hrs)	60 hrs					
Students attended (Course and Year wise) (Enclose attendance sheet of the programme)	Course	Group	Students attended			
			1 st year	2 nd year	3 rd year	Total
	B.sc	MPC , CBZ			59	59
Feed Back about trainer (Excellent/Good/Average/ Bad)	Excellent					
Feedback about programme	Excellent					
Suggestions / Remarks						

SPOC Signature:

10/3/2020

SPOC Name:

M. Vidya Kalpana

Date:

Principal Signature

10. 3. 2020

Principal Name

Dr. K. MALYADRI, M.Com, Ph.D.

PRINCIPAL

SGA GOVT. DEGREE COLLEGE

Yellamanchili, Visakhapatnam Dt. (A.P)-531055

SGA Govt. Degree College, Yellamanchili

Department of Botany

ICT Class for III CBZ, 2021-22



Name: Dr. B. Chandramouli Topic: *Alstonia scholaris* Date: 07-02-2022



Name: Dr. B. Chandramouli Topic: *Zingiber officinale* Date: 07-02-2022

SGA Govt. Degree College, Yellamanchili
Department of Botany
ICT Classes for 2021-22



Name: Smt.V.Padmaja Topic: Endosperm culture Date: 08-02-2022



Smt V. Padmaja, Lecturer in Botany Explaining the culture of Endosperm



SRI GURAJADA APPA RAO GOVERNMENT DEGREE COLLEGE



Vijilankuntla - 531055, ANDHRA PRADESH

Department of Botany

ICT Class for I CBZ (SEM-II), 2021-22

Topic: Anomalous secondary growth in Boerhavia stem

Resource person: Dr. B. Chandramouli

Date: 18-02-2022



Dr. B. Chandramouli, Lecturer in Botany Explaining the Boerhavia stem T.S



SRI GURAJADA APPARAO GOVERNMENT DEGREE COLLEGE

(Re-accredited by NAAC with 'A' Grade, Affiliated to Andhra University)

VELLAMANCHILI- 531055, ANDHRA PRADESH



DEPARTMENT OF PHYSICS

ICT CLASSES (2016-2021)

S.NO	DATE	NAME OF THE LECTURER	GROUP	NAME OF THE TOPIC
1.	23-11-2017	Sri B. Nageswara Rao, Lecturer in physics	MPC, MPCs	Logic Gates
2.	09-08-2018	Sri B. Nageswara Rao, Lecturer in physics	MPC, MPCs	Kepler Laws
3.	10-07-2019	Sri B. Nageswara Rao, Lecturer in physics	MPC, MPCs	Hydrogen Spectrum
4.	27-10-2021	Sri K. Venkanna, Lecturer in physics	MPC, MPCs	Various opportunities in scientific institutes and their present role in nation's development
5.	26-11-2021	Sri P S Jaggarao, Lecturer in physics	MPC, MPCs	Renewable energies
6.	03-12-2021	Sri P S Jaggarao, Lecturer in physics	MPC, MPCs	Opportunities in physics
7.	07-12-2021	Sri P S Jaggarao, Lecturer in physics	MPC, MPCs	Solar energy

In-charge of the department

Head of the Department
Department of Physics
S.G.A. Govt. Degree College
Yellamanchili-531055
ANAKAPALLI District



Principal

Principal
S.G.A. Govt. Degree College

Yellamanchili-531055
ANAKAPALLI District



S.G.A.GOVERNMENT DEGREE COLLEGE

(Re-accredited by NAAC with 'A' Grade, Affiliated to Andhra University)

YELLAMANCHILI - 531055, ANDHRA PRADESH



DEPT.OF ECONOMICS

CERTIFICATE COURSE: 2021-22

M.S. WORD



S.G.A.GOVERNMENT DEGREE COLLEGE

(Re-accredited by NAAC with 'A' Grade, Affiliated to Andhra University)

YELLAMANCHILI - 531055, ANDHRA PRADESH



31-01-2022

DEPARTMENT OF ECONOMICS

DEPARTMENTAL MEETING

Minutes of meeting

The faculty of department of economics met on 31-01-2022 and discussed the following matters

- 1. Resolve to start an add-on course in the Department of economics**
- 2. To submit a letter to principal for getting the permission to start Certificate Course MS WORD**
- 3. To prepare syllabus to the Certificate Course**
- 4. To start the students with a minimum of 20 students.**
- 5. To conduct three weeks (21 days) teaching and practical hours.**
- 6. To conduct EXAM at end of the course and to issue course completion Certificates to successfully completed students.**
- 7. Permission to conduct the add on course by the economics faculty.**
- 8. Permission to utilize JKC Computers**



S.G.A.GOVERNMENT DEGREE COLLEGE

(Re-accredited by NAAC with 'A' Grade, Affiliated to Andhra University)

YELLAMANCHILI - 531055, ANDHRA PRADESH



PERMISSION LETTER TO START CERTIFICATE COURSE

FROM

Head of the Department,
Department Of Economics
SGA Govt. Degree College
Yellamanchill.

TO

The Principal,
S.G.A.Govt.Degree College,
Yellamanchili.

Sub: Permission to start Certificate course (short term course)- Regarding

REF: Resolution copy of the department of economics.

Respected sir,

As per the resolution of the department of economics we are very much interested to start Certificate course (short term course) with a title Microsoft office word for the B.A (HERI) students ,so we are requesting you to give permission to start that add on course and also permit us to act as the faculty for the add-on course.

Thanking you sir,



S.G.A.GOVERNMENT DEGREE COLLEGE

(Re-accredited by NAAC with 'A' Grade, Affiliated to Andhra University)

YELLAMANCHILI - 531055, ANDHRA PRADESH



DEPARTMENT OF ECONOMICS

SYLLABUS

Course Content:

M.S Windows, Computer Basics

Creating folders, Directories, Input units, Output unit, Central processing units what is hardware and Software, Windows short cut keys

Module 1: Text Basics

Typing the text, Alignment of text, Editing Text: Cut, Copy, Paste, Select All, Clear, Find & Replace

Module 2: Text Formatting and saving file:

New, Open, Close, Save, Save As, Formatting Text: Font Size, Font Style Font Color, Use the Bold, Italic, and Underline, Change the Text Case, Line spacing, Paragraph spacing, Shading text and paragraph.

Module 3: Working with Objects:

Shapes, Clipart and Picture, Word Art, Smart Art, Columns and Orderings - To Add Columns to a Document, Change the Order of Objects, Page Number, Date & Time, Inserting Text boxes, Inserting Word art, Inserting symbols, Inserting Chart

Module 4: Header & Footers:

Inserting custom Header and Footer, Inserting objects in the header and footer, Add section break to a document.



Module 5: Working with bullets and numbered lists:

Multilevel numbering and Bulleting, Creating List, Customizing List style, Pagebordering, Page background.

Module 6: Tables:

Working with Tables, Table Formatting, TableStyles, Alignment option Merge and split option.

Module 7: Styles and Content:

Using Build- in Styles, Modifying Styles , Creating Styles, Creating a list style ,Table of contents and references ,Adding internal references ,Adding a Footnote ,Adding Endnote

Module 8: Merging Documents:

Typing new address list , Importing address list from Excel file , Write and insert field ,Merging with outlook contact ,Preview Result , Merging to envelopes ,Merging to label ,Setting rules for merges ,Finish & Merge options

Module 9: Sharing and Maintaining Document:

Changing Word Options, Changing the Proofing Tools, ManagingTemplates, Restricting Document Access, Using Protected View, Working with Templates, ManagingTemplates, Understanding building blocks

Module 10: Proofing the Document:

Check Spelling As You Type. , Mark Grammar Errors as You Type, Setting AutoCorrect Options

Module 11: Printing:

Page Setup, Setting margins, Print Preview, Print



S.G.A.GOVERNMENT DEGREE COLLEGE

(Re-accredited by NAAC with 'A' Grade, Affiliated to Andhra University)

YELLAMANCHILI - 531055, ANDHRA PRADESH



MS-OFFICE word

ASHORT TERM CERTIFICATE COURSE

CLASS ATTENDANCE-II B.A

FEBRUARY-2022

S.NO	NAME OF THE STUDENT	REG.NO	1	2	3	4	5	7	8	9	10	11	14	15	16	17	18	19	21	22	23	24	25	Signatur of the Student
1	A.KONDA BABU	120135401001	P	P	P	P	P	P	P	P	A	P	P	P	A	P	P	P	P	P	P	P	P	
2	B .GOWRI DEVI	120135401002	A	P	P	P	A	A	A	A	A	A	A	P	P	P	P	A	A	A	A	A	A	
3	CH.HARSHAVARDHAN	120135401003	P	P	P	A	P	A	P	P	A	P	P	A	A	A	A	P	P	P	P	A	A	
4	D.A.V.V.S.N.MURTHY	120135401004	P	A	A	P	A	P	P	A	A	A	A	A	P	P	P	P	A	A	P	P	A	
5	D.PAVANKUMARI	120135401005	P	P	A	A	P	P	P	P	P	P	A	P	P	P	A	P	P	P	P	P	P	
6	E.SARASWATHI	120135401007	P	P	P	P	P	P	P	P	P	P	P	P	P	P	P	A	P	P	P	P	P	
7	K.SRINUVASURAO	120135401008	P	A	A	P	P	P	A	A	A	A	A	A	A	P	P	P	P	A	P	A	P	
8	K.MOHAN	120135401009	P	P	A	A	A	A	A	A	A	A	A	A	A	A	A	P	P	A	A	A	A	
9	K.DURGA PRASAD	120135401011	P	P	A	P	P	P	P	P	P	A	A	P	P	P	P	P	P	P	A	P	P	
10	K.APPALARAJU	120135401013	P	P	A	A	A	P	A	P	P	P	A	A	P	A	P	P	P	A	A	A	P	
11	P.MUNNA	120135401015	P	P	A	P	P	P	A	P	A	A	A	P	P	P	A	A	P	A	P	P	A	
12	P DURGAPRASAD	120135401016	P	P	A	A	A	A	A	P	P	A	P	A	P	A	P	P	P	A	A	A	P	
13	R.VENKATA LAKSHMI	120135401017	P	P	P	P	P	P	P	P	P	P	P	P	A	P	P	P	P	A	P	P	P	
14	R.GANESH	120135401018	P	P	A	A	P	A	P	A	P	P	P	P	A	P	P	A	P	P	P	P	P	
15	R. B.APARNA	120135401019	P	P	P	P	P	P	P	P	P	P	P	P	A	P	P	P	P	P	P	P	P	
16	S. DHANA LAKSHMI	120135401020	P	P	P	P	A	P	P	P	P	P	P	A	A	P	A	P	P	P	P	P	P	
17	Y RAMATEJA	120135401021	P	P	A	P	P	P	P	P	A	P	P	P	P	A	A	A	P	P	P	P	P	
18	B.TEJA RUPINI	121135401007	P	P	P	P	P	A	A	P	P	P	P	P	A	P	P	P	P	A	P	P	P	
19	G.NOOKARATNAM	121135401010	P	P	P	P	P	P	P	P	P	A	P	P	P	P	P	P	P	P	P	P	P	
20	P.VINAYA KUMAR	121135401015	P	P	P	P	P	P	P	P	P	P	A	P	A	P	P	P	P	P	P	P	P	
21	Y.SAI DURGA	121135401021	P	P	P	P	P	A		P	A	P	P	P	P	A	P	P	P	A	P	P	P	

Signature of the Coordinator

Signature of the Principal



Final exam paper

Certificate course

Department of Economics 25 MARKS

1)MS word is software of ____

- (A) Apple (B) Android
(C) Google (D) Microsoft

2)The valid format of MS Word is ____

- (A) .exe (C) .png
(B) .doc (D) .jpeg

3)"Www" stands for:

- (A) World Wide Web (C) World Wide Wait
(B) World Wide Wares (D) World Wide War

4)What does CPU stand for?

- (A) Cute People United (C) Computer Parts of USA
(B) Commonwealth Press Union (D) Central Processing Unit

5)Which is not an Internet protocol?

- (A) HTTP (C) STP
B) FTP(D) IP

6)TXT' extension refers usually to what kind of file?

- (A) Text File (C) Audio file
(B) Image file (D) Adobe Acrobat files



7)What's a web browser?

(A) A kind of spider (C) A person who likes to look at websites(B) A computer that stores WWW files(D) A software program that allows you to access sites on the World Wide Web

8)Which of the following to justification align the text on both the sides-left and right of margin?

(A) Balanced (C) Justify

(B) Right (D) Balanced

9)Line spacing is in the ____ of MS Word.

(A) Format tab (C) Insert tab

(B) View tab(D) Home tab

10)____ button reduces the window to an icon but word still remains active.

(A) Close(C) Maximize

(B) Restore

(D) Minimize

11) What is the smallest width of a column?

(A) 0" (C) 0.5"

(B) 1" (D) 1.5"

12)Arial, Cambria, Verdana, Times New Roman are the name of ____

(A) Highlights (C) Text

(B) Font face (D) Alignment

13)To make the selected text bold, the shortcut key is ____

(A) Alt+ B (C) Ctrl+ B

(B) Shift+ B(D) Space +H



14) Which of the following is not an option in clipboard?

- (A) Cut (C) Paste
- (B) Copy (D) Page setup

15) Changing the appearance of a document is called as ____

- (A) Page orientation (C) Finding
- (B) Editing (D) Formatting

16) Zoom in and out button is available on

- (A) Scroll bar (C) Page layout tab
- (B) Home tab (D) View option toolbar

17) What is the blinking symbol on the screen that shows where the next character will appear?

- (A) Cursor (C) Arrow key
- (B) Delete key (D) Return key

18) What is a note or annotation that an author or reviewer adds to a document?

- (A) Comment (C) Header
- (B) Caption (D) Footer

19) The document can be zoomed maximum up to

- (A) 150% (C) 400%
- (B) 200% (D) 500%

20) ____ refers to back the object to one level or to all objects.

- (A) Align (C) Bring to front
- (B) Rotate (D) Send to back

21) ____ refers to a title for a part of a document.



(A) Leader characters (C) Header

(B) Indent(D) Heading

22)What is the ghosted text or picture behind the content on the page?

(A) Clipart(C) WordArt

(B) Watermark (D) All of these

23)In MS word we insert

(A) Page number(C) Table

(B) Text Box(D) All of these

24)Which is not a page size in MS Word document?

(A) A3

(C) Letter

(B) A4

(D) Z100

25) User can use _____ commands to search for and correct words in a document.

(A) Copy and Paste

(C) Header and Footer

(B) Find and Replace

(D) Print and Print preview

ADD-ON COURSE: M.S OFFICE WORD ANSWER KEY

1).D 2).B 3).A 4).D 5).C 6)A 7).D 8)C 9).D 10).D 11).C

12)B 13)C 14).D 15).D 16).D 17).A 18).A 19).D 20)D

21)D 22).B 23).D 24).D 25).B



S.G.A.GOVERNMENT DEGREE COLLEGE

(Re-accredited by NAAC with 'A' Grade, Affiliated to Andhra University)

YELLAMANCHILI - 531055, ANDHRA PRADESH



S.G.A. GOVERNMENT DEGREE COLLEGE

(Affiliated to Andhra University)

Accredited By NAAC with "A" Grade

Yellamanchili Visakhapatnam Andhra Pradesh



COURSE COMPLETION CERTIFICATE

This certificate is awarded to Sri/Kum_____ of I and II B.A (HERI) on completion of Certificate Course in "MS-WORD", organised by Department of Economics for the Academic year 2021-22.

Course co-ordinator
HOD, Department of Chemistry

Course resource person

Principal



S.G.A.GOVERNMENT DEGREE COLLEGE

(Re-accredited by NAAC with 'A' Grade, Affiliated to Andhra University)

YELLAMANCHILI - 531055, ANDHRA PRADESH



DEPARTMENT OF ECONOMICS

Certificate Course' for the academic year 2021-22

SUMMARY REPORT

The department of Economics has started **Certificate Course on 'MS WORD'** with 21 students from **B.A.** second years of SGA GDC. Department of Economics conducted 21 classes to complete the syllabus within stipulated time from 01-02-2022 to 25-02-2022. The exams were conducted to registered students for 25 marks and issued certificates to all students.

Mutual Funds Subject is one of the important employment fields in present era. There are ample opportunities for students in MS office in the job market. So Department of Economics introduced this course for the benefit of students in their future. All the students were presented and gained practical knowledge in MS WORD.

1. Number of students enrolled: 21
2. Number of students completed: 21
3. Classes conducted : 21 hours
4. Maximum marks: 25 marks
5. Time: morning and evening 1 hour.

Course Co - Ordinator

Principal



S.G.A.GOVERNMENT DEGREE COLLEGE

(Re-accredited by NAAC with 'A' Grade, Affiliated to Andhra University)

YELLAMANCHILI - 531055, ANDHRA PRADESH



S.G.A. GOVERNMENT DEGREE COLLEGE

(Affiliated to Andhra University)

Accredited By NAAC with "A" Grade

Yellamanchili Visakhapatnam Andhra Pradesh



COURSE COMPLETION CERTIFICATE

This certificate is awarded to Sri/Kum_____ of I and II B.A (HERI) on completion of Certificate Course in "MS-WORD", organised by Department of Economics for the Academic year 2021-22.

Course co-ordinator
HOD, Department of Chemistry

Course resource person

Principal